



mangOH™ Red

Developer's Guide



**IMAGE TO BE REPLACED
WITH DV3 WHEN AVAILABLE**

Important Notice

Due to the nature of wireless communications, transmission and reception of data can never be guaranteed. Data may be delayed, corrupted (i.e., have errors) or be totally lost. Although significant delays or losses of data are rare when wireless devices such as the Sierra Wireless modem are used in a normal manner with a well-constructed network, the Sierra Wireless modem should not be used in situations where failure to transmit or receive data could result in damage of any kind to the user or any other party, including but not limited to personal injury, death, or loss of property. Sierra Wireless accepts no responsibility for damages of any kind resulting from delays or errors in data transmitted or received using the Sierra Wireless modem, or for failure of the Sierra Wireless modem to transmit or receive such data.

Safety and Hazards

Do not operate the Sierra Wireless modem in areas where blasting is in progress, where explosive atmospheres may be present, near medical equipment, near life support equipment, or any equipment which may be susceptible to any form of radio interference. In such areas, the Sierra Wireless modem **MUST BE POWERED OFF**. The Sierra Wireless modem can transmit signals that could interfere with this equipment.

Do not operate the Sierra Wireless modem in any aircraft, whether the aircraft is on the ground or in flight. In aircraft, the Sierra Wireless modem **MUST BE POWERED OFF**. When operating, the Sierra Wireless modem can transmit signals that could interfere with various onboard systems.

Note: Some airlines may permit the use of cellular phones while the aircraft is on the ground and the door is open. Sierra Wireless modems may be used at this time.

The driver or operator of any vehicle should not operate the Sierra Wireless modem while in control of a vehicle. Doing so will detract from the driver or operator's control and operation of that vehicle. In some states and provinces, operating such communications devices while in control of a vehicle is an offence.

Limitation of Liability

The information in this manual is subject to change without notice and does not represent a commitment on the part of Sierra Wireless. SIERRA WIRELESS AND ITS AFFILIATES SPECIFICALLY DISCLAIM LIABILITY FOR ANY AND ALL DIRECT, INDIRECT, SPECIAL, GENERAL, INCIDENTAL, CONSEQUENTIAL, PUNITIVE OR EXEMPLARY DAMAGES INCLUDING, BUT NOT LIMITED TO, LOSS OF PROFITS OR REVENUE OR ANTICIPATED PROFITS OR REVENUE ARISING OUT OF THE USE OR INABILITY TO USE ANY SIERRA WIRELESS PRODUCT, EVEN IF SIERRA WIRELESS AND/OR ITS AFFILIATES HAS BEEN ADVISED OF THE POSSIBILITY OF SUCH DAMAGES OR THEY ARE FORESEEABLE OR FOR CLAIMS BY ANY THIRD PARTY.

Notwithstanding the foregoing, in no event shall Sierra Wireless and/or its affiliates aggregate liability arising under or in connection with the Sierra Wireless product, regardless of the number of events, occurrences, or claims giving rise to liability, be in excess of the price paid by the purchaser for the Sierra Wireless product.

Patents

This document contains information which is proprietary to Sierra Wireless Inc. and is licensed pursuant to Creative Commons Attribution 4.0 International License.

Document details

Title: mangOH Red Developer's Guide

Author: Sierra Wireless

Source: <http://mangoh.io/>

Copyright

© 2017 Sierra Wireless. Licensed under the Creative Commons Attribution 4.0 license, <http://creativecommons.org/licenses/by/4.0/>



Disclaimer

Indicate any modifications made to the original document.

Trademarks

mangOH™ and the mangOH logo are trademarks of Sierra Wireless.

Other trademarks are the property of their respective owners.

Revision History

Revision number	Release date	Changes
1	May 2016	Document created

Contents

Introduction	5
Hardware	6
mangOH Red Hardware Overview	6
mangOH Red Hardware Architecture	9
mangOH Red Hardware Components	11
MUXing	16
CF3 Module Signals	16
ADC	16
Audio (Analog and PCM)	17
CF3 GPIOs	17
GPIO Expander	19
HSIC (USB/Ethernet)	19
I2C1	20
Light Sensor	21
Raspberry Pi Rev B-compatible Connector	21
RF	23
SDIO	23
SPI1	24
UART1	24
UART2	25
UART Console Connections	25
UIM Signals	26
USB 2.0	27
Wi-Fi/BT Chipset	28
IoT Connector Interfaces	30
Reset Methods	31
Power Management	31

1: Introduction

The mangOH Red open-source hardware development platform for CF3 modules incorporates several hardware interfaces and a standardized IoT Expansion Card slot for expanded functionality.

This developer's guide describes the mangOH Red's architecture and provides details on how to develop applications for CF3 modules.

For the full mangOH Red documentation suite, refer to mangoh.io.

DRAFT

2: Hardware

This chapter describes the mangOH Red platform’s hardware components and interfaces.

mangOH Red Hardware Overview

Figure 2-1 provides an overview of the mangOH Red’s hardware components relative to the CF3 module, and Figure 2-2 on page 7 and Figure 2-3 on page 8 shows their physical locations.

For additional details, see the following documents available at mangoh.io:

- mangOH Red User Guide—Instructions on setting up the hardware components
- Sierra Wireless CF3 module-specific Product Technical Specification documents
- AirPrime Embedded Module Common Flexible Form Factor (CF3) Specification

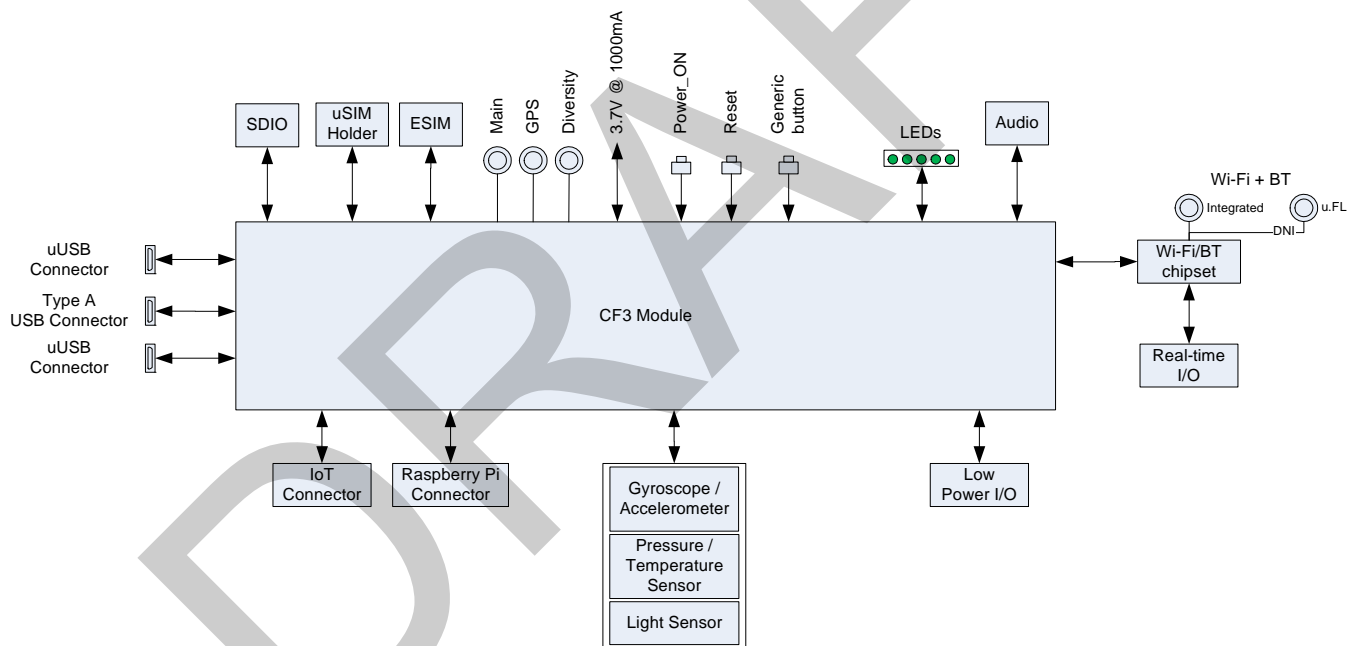

Figure 2-1: mangOH Red Hardware Components Overview

- 1—Pluggable IoT connector (CN306 (IOT0))
- 2—Power supply select (CN804)
- 3—Battery connector (CN802)
- 4—Signals control (SW401)
- 5—Main antenna (CN301)
- 6—GNSS antenna (CN303)
- 7—Diversity antenna (CN302)
- 8—Wi-Fi/Bluetooth antenna (ANT1000)
- 9—USB Host (CN304)
- 10—Audio (CN500)
- 11— μ USB Console connector (CN305)
- 12—Raspberry PI RevB-compatible header (CN307)
- 13—Generic button (SW200)
- 14—PWR_ON switch (SW402)
- 15—Reset switch (SW400)
- 16—CF3 module socket (J200)
- 17—Real Time I/O (CN310)
- 18—Low Power I/O (CN312)

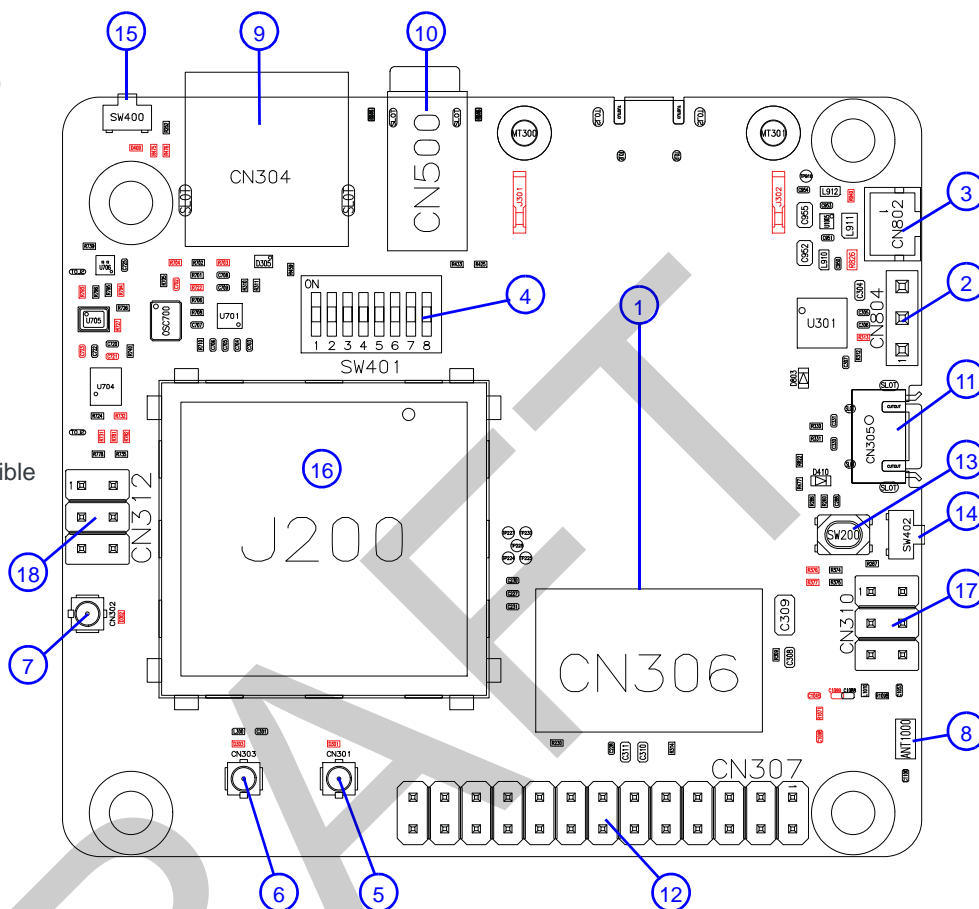

Figure 2-2: mangOH Red—Top Side Switches/Connectors

Note: For reference only. For latest schematic, visit mangoh.io.

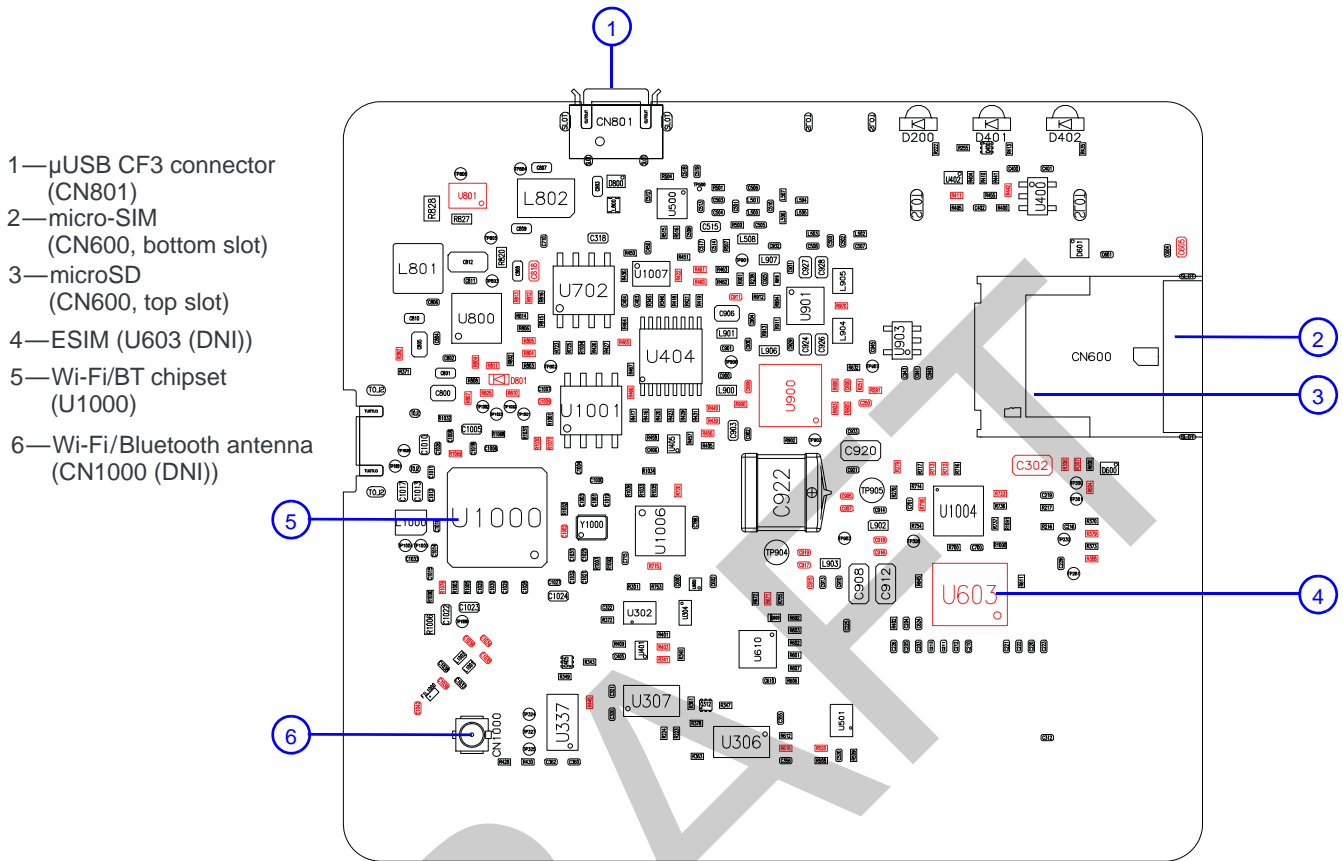

Figure 2-3: mangOH Red—Bottom Side Switches/Connectors

Note: For reference only. For latest schematics, visit mangoh.io.

mangOH Red Hardware Architecture

The mangOH Red platform provides several hardware components, including:

- CF3 module socket
- Wi-Fi/BT chipset (MediaTek Wi-Fi+Bluetooth)
- Pluggable IoT Connector (socket for IoT Expansion Card)
- Raspberry Pi Rev B-compatible 26-pin connector
- Several I/O connectors (SIM, SD, Audio, USB, etc.)

[Figure 2-4](#) illustrates the mangOH Red's hardware architecture (connectors and signals). The following sections describe these features in greater detail:

- [mangOH Red Hardware Components](#) on page 11—Components available to the CF3 module and Wi-Fi/BT chipset.
- [CF3 Module Signals](#) on page 16—CF3 module connections to hardware components.
- [Wi-Fi/BT Chipset](#) on page 28—Wi-Fi/BT chipset connections to hardware components.
- [IoT Connector Interfaces](#) on page 30—IoT Expansion Card signal connections to the hardware components.

DRAFT

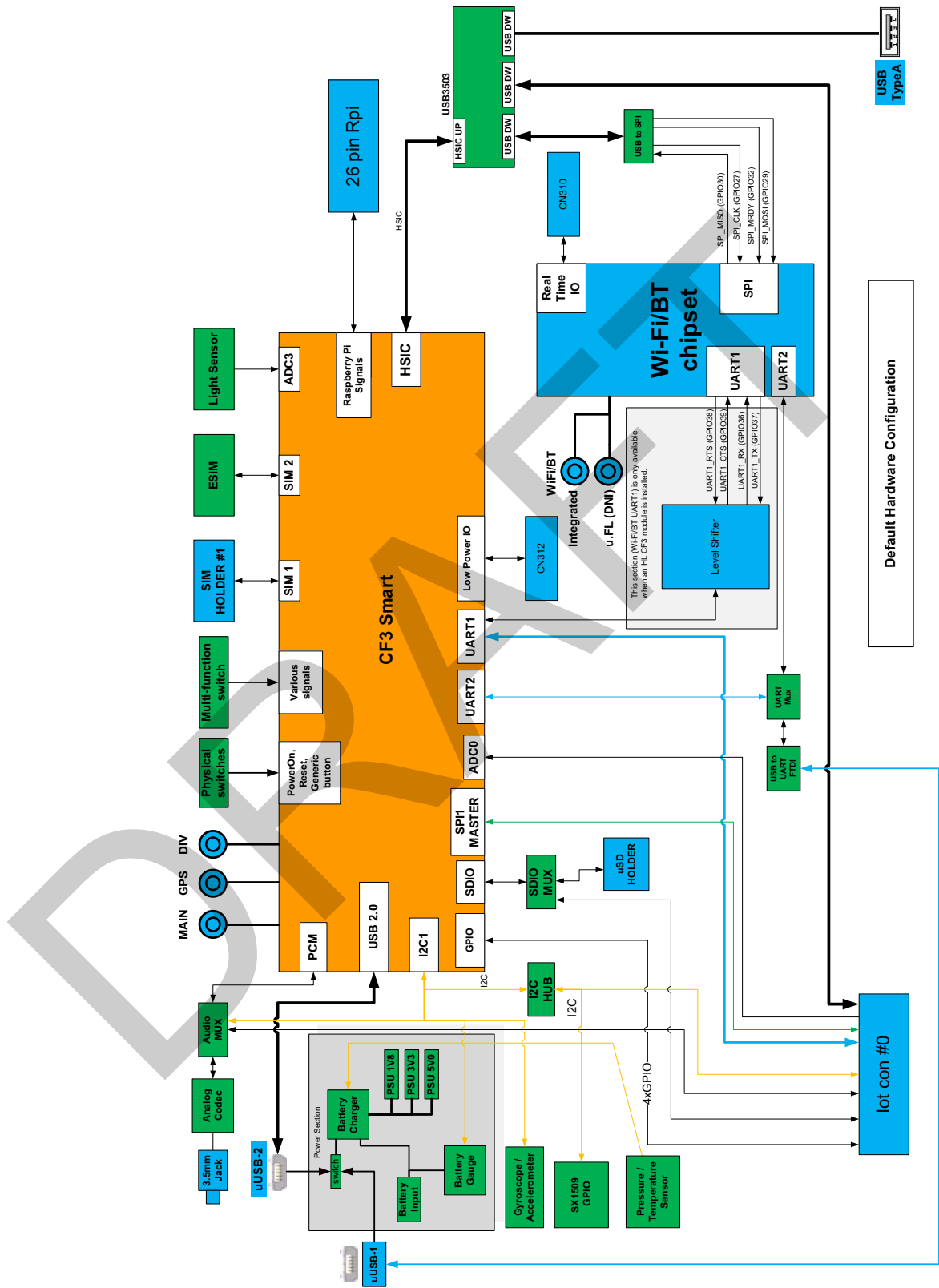

Figure 2-4: mangOH Red Hardware Architecture (Default)

mangOH Red Hardware Components

Key mangOH Red hardware components and their connections to the CF3 module and/or Wi-Fi/BT chipset are listed in [Table 2-1](#) on page 11.

The mangOH Red's default configuration enables specific interfaces when the platform boots. For interface details, see:

- [MUXing](#) on page 16
- [CF3 Module Signals](#) on page 16
- [Wi-Fi/BT Chipset](#) on page 28
- [IoT Connector Interfaces](#) on page 30
- [Reset Methods](#) on page 31
- [Power Management](#) on page 31

Table 2-1: mangOH Red Hardware Components

Type and Designator ^a	Description	Signals/Module Pins	Notes
Modules/Processors/etc.			
CF3 module (J200)	For details, see CF3 Module Signals on page 16.		
IOT0 (CN306)	IoT Expansion Card	Connections to multiple CF3 module interfaces.	For details, see IoT Expansion Card on page 14.
Wi-Fi/BT chipset (U1000)	MediaTek Wi-Fi/BT chipset with ARM Cortex-M4 application processor	For details, see Wi-Fi/BT Chipset on page 28.	
Card slots			
Micro-SIM (CN600)	Micro-SIM/microSD holder (bottom slot)	CF3 UIM1 (Pins: 26–29)	Purpose: UIM used to establish mobile network connection. For details, see UIM1 on page 27.
micro-SD (CN600)	Micro-SIM/microSD holder (top slot)	CF3 SDIO (Pins: 161–166)	Purpose: Provide access to microSD card. For details, see: <ul style="list-style-type: none"> • SDIO on page 23 • MUXing on page 16
ESIM (U603)	Embedded SIM	CF3 UIM2 (Pins 55–58)	Purpose: Built-in UIM used to establish mobile network connection. For details, see UIM2 on page 27. <i>Note: eSIM is DNI.</i>

Table 2-1: mangOH Red Hardware Components (Continued)

Type and Designator ^a	Description	Signals/Module Pins	Notes
USB-type connectors			
micro-USB (CN801)	CF3 USB micro-USB connector	<ul style="list-style-type: none"> USB (Pins: 12, 13, 16) Power (if selected) 	Purpose: <ul style="list-style-type: none"> Direct connection to CF3 USB Power supply when selected by the Power Supply Selection Jumper (CN804). See mangOH Red User Guide for details. For details, see USB 2.0 on page 27.
micro-USB (CN305)	Console USB micro-USB connector	<ul style="list-style-type: none"> UART2 (Pins: 96–99) Power (if selected) 	Purpose: <ul style="list-style-type: none"> Console—Connects to CF3 module console or Wi-Fi/BT chipset console Power supply when selected by the Power Supply Selection Jumper (CN804). See mangOH Red User Guide for details. For details, see UART2 on page 25.
USB Host (CN304)	USB Type A connector	HSIC (Pins: 14, 15)	Purpose: Provides USB host capability to CF3 module. For details, see HSIC (USB/Ethernet) on page 19.
RF, Audio, Raspberry Pi connectors			
RF Antennas Main (CN301) GNSS (CN303) Diversity (CN302)	u.FL connectors	CF3 RF (Pins: 49 (Main), 38 (GNSS), 31 (Diversity))	For details, see RF on page 23.
Wi-Fi/Bluetooth Antennas (Integrated—ANT1000; u.FL—CN1000 (DNI))	Antenna	Wi-Fi/BT chipset RF	For details, see Wi-Fi/BT Chipset on page 28.
Audio (CN500)	3.5 mm connector	CF3 digital audio signals (Pins: 30–33)	Purpose: Provide audio capability to CF3 module. For details, see: <ul style="list-style-type: none"> Audio (Analog and PCM) on page 17 MUXing on page 16
Raspberry Pi (CN307)	26-pin Rev B-compatible connector	<ul style="list-style-type: none"> CF3 HSIC signals (via SPI or USB (DNI)) Wi-Fi/BT chipset SPI 	For details, see Raspberry Pi Rev B-compatible Connector on page 21.
Other ICs and components			
Gyroscope/ Accelerometer (U704)	Integrated BMI160 inertial measurement module	CF3 I2C1 interface	Purpose: Provides rotational, linear motion, and gravitational force measurements for use in (for example) gaming, mapping, navigation, and optical image stabilization applications. For details, see I2C1 on page 20.

Table 2-1: mangOH Red Hardware Components (Continued)

Type and Designator ^a	Description	Signals/Module Pins	Notes
Pressure sensor/ Temperature sensor (U705)	Integrated BMP280 barometric pressure sensor	CF3 I2C1 interface	Purpose: Provides barometric pressure, altitude, and temperature measurements for use in (for example) GPS navigation, indoor/outdoor navigation, and weather forecasting applications. For details, see I2C1 on page 20.
Light sensor (U706)	Integrated PNJ4K01F ambient light sensor	CF3 ADC3	Purpose: Provide ambient light measurements for use in (for example) brightness control systems. For details, see Raspberry Pi Rev B-compatible Connector on page 21.
GPIO/PWM expander (U1004)	Integrated SX1509 expander	CF3 I2C1 interface	Purpose: Provides additional GPIOs. For details, see: <ul style="list-style-type: none"> GPIO Expander on page 19 I2C1 on page 20
Low Power I/O connector (CN312)	6-pin header	CF3 ADC1/ADC2 CF3 GPIOs (if resistors are populated) CF3 UIM2_DET	Purpose: Connect low-power input sources to CF3 module. For details, see ADC on page 16.
Real-time I/O connector (CN310)	6-pin header	Wi-Fi/BT chipset user- configurable multi-purpose pins (for ADC, GPIO, PWM, I2C, etc.)	Purpose: Connect input sources to Wi-Fi/BT chipset for use by its real-time application processor. (Multi-purpose pin details forthcoming.) For details, see Wi-Fi/BT Chipset on page 28.
LEDs			
IoT Expansion Card 0 (D401)	Green LED	GPIO expander I/O_8 via LED_CARD_DETECT_IOT0	Purpose: Indicates IoT Expansion Card is in slot IOT0.
Rx/Tx (CF3 module) (D402)	Green LED	CF3 TX_ON	Purpose: Indicates CF3 module is transmitting/receiving.
WLAN Connected (D200)	Green LED	CF3 WWAN_LED_N	Purpose: Indicates device is connected to a WLAN (will be OFF when LowPower Mode is enabled).
VCC_3V3 (D803)	Green LED	VCC_3V3	Purpose: Indicates device is powered on.
Generic (user- defined) (D410)	Green LED	CF3 GPIO34 (via expander WP_GPIO_7_lvl)	Purpose: User-defined (programmable)

Table 2-1: mangOH Red Hardware Components (Continued)

Type and Designator ^a	Description	Signals/Module Pins	Notes
Platform controls			
Multi-switch (SW401)	Module signals control	Eight dipswitches:	
		1. PWR_ON	Enable/disable CF3 module's POWER_ON signal
		2. WIFI_UART1_TX	Enable (On)/disable (Off) firmware download (recovery mode) to the CF3 module. Similar functionality to TP1_BOOT.
		3. VCC_3V7_ULPM	When device is in ULPM: <ul style="list-style-type: none"> • OFF—only the CF3 module is receiving power. • ON—the CF3 module + accessories receive power
		4. HL_MODE	Used with pin 8 (LowPower_RESET) to indicate whether in HL mode or WP mode <ul style="list-style-type: none"> • ON—HL mode • OFF—WP mode
		5. BATT_TS+	Enable (On)/disable (off) battery charging
		6. CONS_DIR	Console USB connectors connects to: <ul style="list-style-type: none"> • OFF—CF3 module console • ON—Wi-Fi/BT chipset console Note: To download firmware to the: <ul style="list-style-type: none"> • CF3 module—Set CONS_DIR Off and TP1_BOOT On. • Wi-Fi/BT chipset—Set CONS_DIR On and WIFI_UART_TX On.
		7. TP1_BOOT	Enable (On)/disable (Off) CF3 module's TP1 (boot) signal.
8. LowPower_RESET	Used with pin 4 to indicate whether in HL mode or WP mode <ul style="list-style-type: none"> • ON—WP mode • OFF—HL mode For details, see Power Management on page 31.		

a. Board designators (e.g. CN311, SW401, etc.) are for reference against the published mangOH Red schematic. For component locations on the board, see [Figure 2-2](#) on page 7 and [Figure 2-3](#) on page 8.

IoT Expansion Card

mangOH Red includes one IoT Expansion Card slot (IOT0), which has an IoT Connector (CN306) that connects to the CF3's signals as detailed in [Table 2-2](#).

This slot provides full support for the IoT Expansion Card specification.

By default, specific signals are enabled when the mangOH Red boots. For additional information, including default configuration and how to temporarily change it, see [IoT Connector Interfaces](#) on page 30.

For detailed specifications, see the Project mangOH IoT Expansion Card Design Specification available at mangoh.io.

Table 2-2: IoT Expansion Card Signal Connections to CF3 Module

IoT Signals	CF3 Signal(s)		Notes
	Signal	Path	
USB	HSIC (Pins 14, 15)	Single	Purpose: Data transfer; application control For details, see HSIC (USB/Ethernet) on page 19.
UART	UART1 (Pins 2, 9)	MUX	Purpose: Data transfer For details, see: <ul style="list-style-type: none"> • UART1 on page 24 • MUXing on page 16
SPI	SPI1 (Pins 51–54)	Yes	Purpose: Data transfer For details, see: <ul style="list-style-type: none"> • SPI1 on page 24 • MUXing on page 16
I2C	I2C1 (Pins 1, 66)	Hub	Purpose: Data transfer (standard mode). Higher speeds possible if supported by host application. For details, see I2C1 on page 20.
GPIOs 1–4	GPIO (7, 8, 13, 42)	Single	Purpose: Customer-defined data communication For details, see CF3 GPIOs on page 17.
SDIO	SDIO (Pins 161–166)	Yes	Purpose: Data transfer For details, see: <ul style="list-style-type: none"> • SDIO on page 23 • MUXing on page 16
ADC0	ADC0 (Pin 25)	Single	Purpose: General purpose ADC output to host application (e.g. indicate when a sensor has triggered) For details, see ADC on page 16.
Power	Power	n/a	Default configuration—Receives three power inputs: <ul style="list-style-type: none"> • 5.0V @ 500 mA • 3.3V @ 1 A • 1.8V @ 200 mA For details, see Power Management on page 31.
PCM	PCM	Single	Purpose: Digital audio interface
RESET_IOT0	GPIO2		Purpose: Data transfer For details, see CF3 GPIOs on page 17.
PPS	DR_SYNC		Purpose: Clock signal used to manage timing for sensor nodes (or other devices) that are connected to the expansion card. The signal is a stratum 1 clock input from the host application, where the host application operates as a stratum 1 time source connected to GPS (a stratum 0 source).
CARD_DETECT_IOT0	GPIO33		Purpose: Data transfer For details, see CF3 GPIOs on page 17.

MUXing

Several interfaces use MUXing (simple switches) to associate multiple hardware connectors with a single signal from the CF3 module, or multiple signals with a single hardware connector.

The following sections describe these MUX implementations

- MUX
 - [Audio \(Analog and PCM\)](#) on page 17
 - [SDIO](#) on page 23
 - [UART2](#) on page 25
- Hubs
 - [HSIC \(USB/Ethernet\)](#) on page 19
 - [I2C1](#) on page 20

CF3 Module Signals

This section describes how CF3 module signals connect to the platform hardware (described in [mangOH Red Hardware Components](#) on page 11).

Important: *CF3 module signal availability depends on the module type—some modules may not implement certain Extension signals from the CF3 specification.*

ADC

The mangOH Red supports four CF3 module ADC (Analog to Digital converter) signal sources (ADC0-ADC3).

The ADC signals connect to the following sources, as shown in [Figure 2-5](#):

- ADC0—IoT Connector 0 (CN1000, slot IOT0), pin 20
- ADC1, ADC2—Low Power I/O (CN312), pins 4 and 5
- ADC3—Light sensor (U706), pin 6

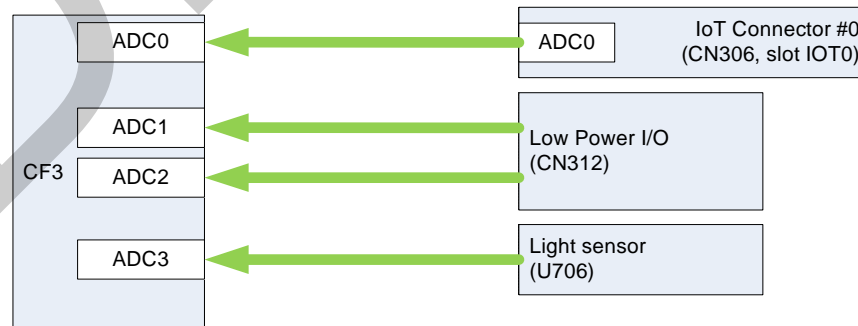

Figure 2-5: ADC Configuration

Audio (Analog and PCM)

The mangOH Red supports the CF3 module PCM (digital) audio signals. The signals connect via a Mux (analog switch) to the following sources, as shown in [Figure 2-6](#) on page 17:

- 3.5 mm analog audio jack (Default configuration)
- IoT connector (Alternate configuration)

The audio interface configuration can be modified as described in [Table 2-3](#).

Table 2-3: Audio Interface Configuration Changes

Change type	Change effect	Method	Change duration
Hardware	Mux—Use default or alternate configuration	Populate/depopulate resistors on the Mux: <ul style="list-style-type: none"> • R508 pulls signal low (default configuration) • R520 pulls signal high (alternate configuration) 	Selected configuration used every time device boots up.

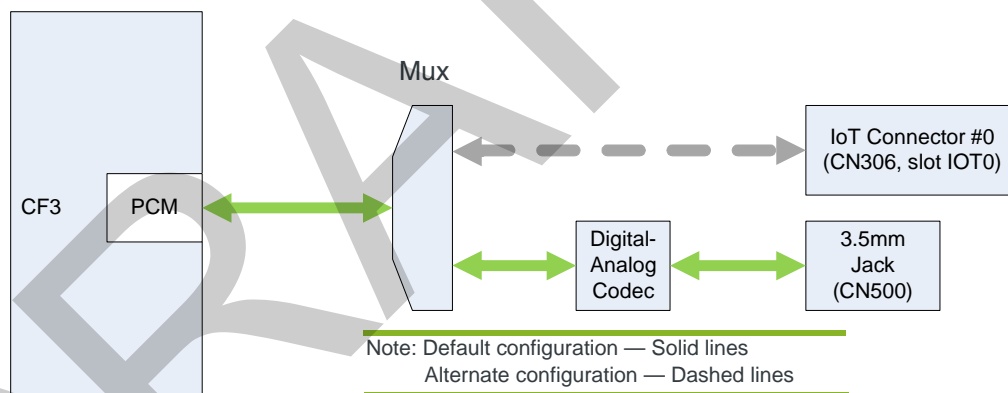

Figure 2-6: Audio Configuration

CF3 GPIOs

The mangOH Red supports several CF3 module GPIOs, as shown in [Figure 2-7](#) on page 18.

Notes:

- Six GPIOs connect to the IoT slot (for card detect, card reset, and four for use as GPIOs).
- One GPIO (GPIO32) connects to the NINT (active low interrupt) output signal from a GPIO expander (U1004).

Note: The mangOH Red uses a GPIO expander for additional I/O functions. See [GPIO Expander](#) on page 19.

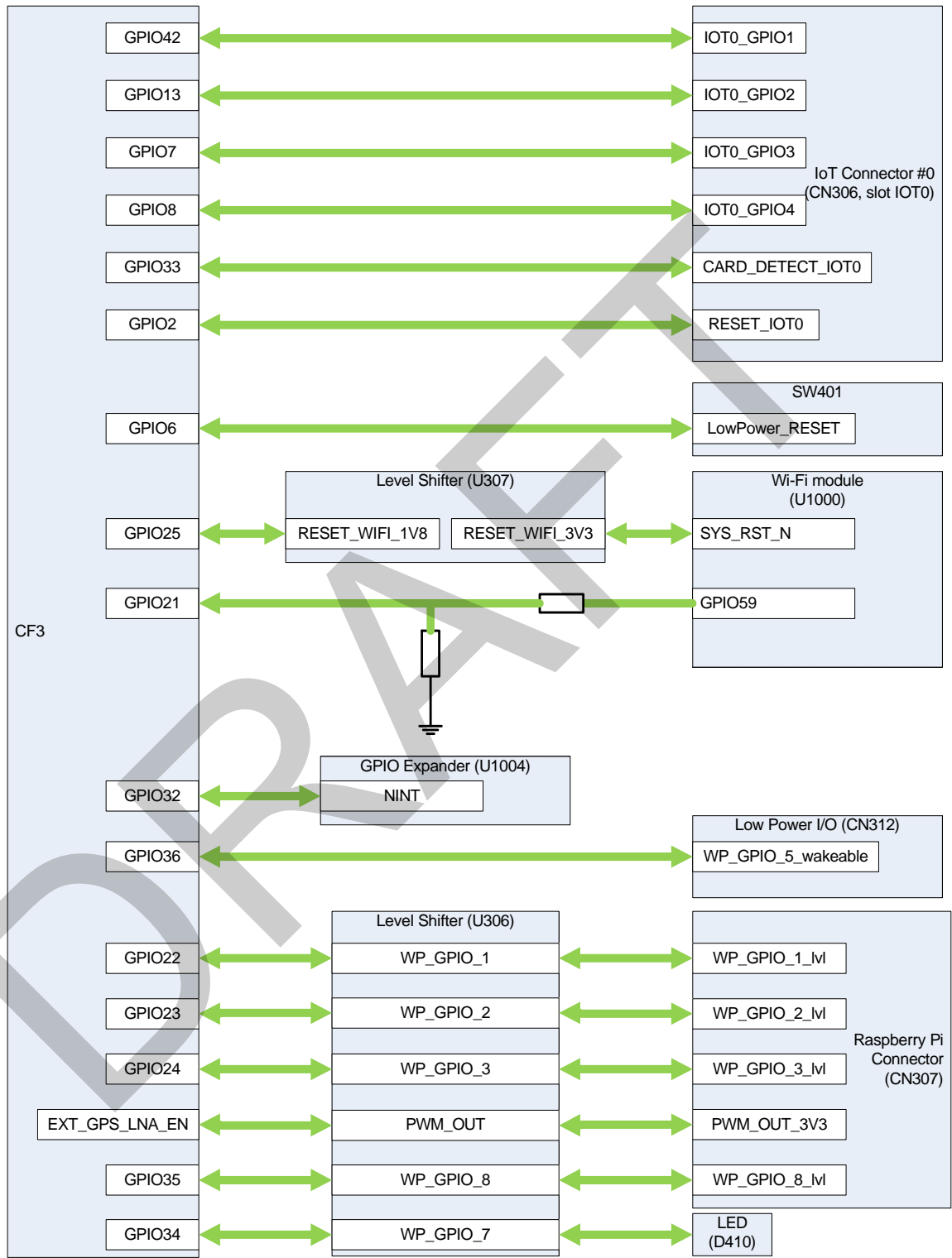

Note: Default configuration — Solid lines
Alternate configuration — Dashed lines

Figure 2-7: GPIO Configuration

GPIO Expander

The mangOH Red includes one SX1509 16-channel GPIO/PWM expander (U1004), as detailed in [Table 2-4](#). The expander provides additional GPIOs (carried over the CF3 module's I2C1 interface) that are used for internal I/O functions such as driving LEDs, resetting board components, etc.

For detailed specifications, see the mangOH Red schematics at mangoh.io.

Table 2-4: GPIO Expander Signals

Desig	Pin	Signal Name	Purpose
U1004	I/O_0	BOARD_REV3	Three pins together indicate the board revision
	I/O_1	BOARD_REV1	
	I/O_2	BOARD_REV2	
	I/O_3	GPIO_EXP_RPI_1	Raspberry Pi connector, pin 16
	I/O_4	GPIO_EXP_RPI_2	Raspberry Pi connector, pin 18
	I/O_5	MTK_TO_WP_UART_EN	Enable MTK recovery mode from WP (0), or connects CF3 UART1 to Wi-Fi/BT chipset UART0 (1)
	I/O_6	WIFI_UART1_TX	Wi-Fi/BT chipset UART Tx—Normal (0), or MTK recovery mode (1) for firmware downloads/recovery
	I/O_7	GPIO_EXP_RPI_3	Raspberry Pi connector, pin 22
	I/O_8	LED_CARD_DETECT_IOT0	Indicates whether IoT expansion card is present
	I/O_9	SDIO_SEL	Connect SD interface to IoT0 (0) or SD card (1)
	I/O_10	Power_Fail_Indicator	Indicate power fail
	I/O_11	SENSOR_INT1	Accelerometer/gyroscope sensor interrupt
	I/O_12	SENSORT_INT2	Accelerometer/gyroscope sensor interrupt
	I/O_13	PCM_EXP1_SEL	Connect PCM interface to IoT0 or to PCM codec (audio)
	I/O_14	Generic_Push_Button	SW200 generic pushbutton
I/O_15	CONS_DIR	Use with MTK_TO_WP_UART_EN to choose UART source -- CF3 module or Wi-Fi/BT chipset	

HSIC (USB/Ethernet)

The mangOH Red supports CF3 module HSIC signals, which connect through a USB hub controller to the following sources, as shown in [Figure 2-8](#) on page 20:

- SPI interface:
 - Wi-Fi/BT chipset (U1000) and Raspberry Pi Connector (CN307), via USB to SPI bridge (U1006).

Note: The Wi-Fi/BT chipset uses SPI2_CS0, and Raspberry Pi connector uses SPI2_CS1/SPI2_CS2.

- USB interface:
 - IoT Connector 0 (CN306)
 - or
 - (DNI) Raspberry Pi Connector (CN307)
 - USB Host connector (CN304)

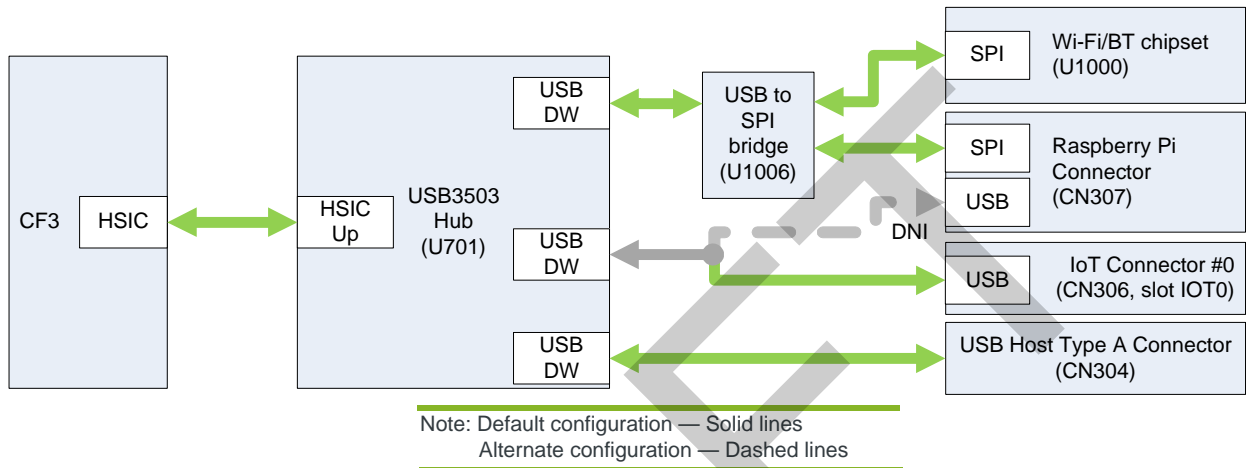

Figure 2-8: HSIC Configuration

I2C1

The mangOH Red supports CF3 module I2C1 signals, which connect to the following sources (directly or via an expander), as shown in [Figure 2-9](#) on page 21:

- Audio codec (U500)
- Pressure sensor (U705)—Accessible via API commands.
- Accelerometer/Gyroscope/Temperature sensor (U704)—Accessible via API commands.
- Battery charger (U800)—Accessible via API commands.
- Battery gauge (U801)—Accessible via API commands.
- IoT Connector 0 (CN306)
- Raspberry Pi connector (CN307)
- GPIO/PWM expander (U1004)—Used internally on the mangOH Red for I/O functions such as driving LEDs, resetting board components, etc. (see [GPIO Expander](#) on page 19)

For detailed information, refer to mangOH Red schematics available at mangoh.io.

- USB Hub controller (U701)

All signal sources are enabled by default.

Note: The mangOH Red I2C interface operates in a single-master/multi-slave setup.

Note: By default, the CF3 I2C interface is connected as shown in Figure 2-9. The board can be modified to connect the Wi-Fi/BT chipset I2C interface to the I2C expander and gyroscope/accelerometer sensor by populating/depopping appropriate resistors.

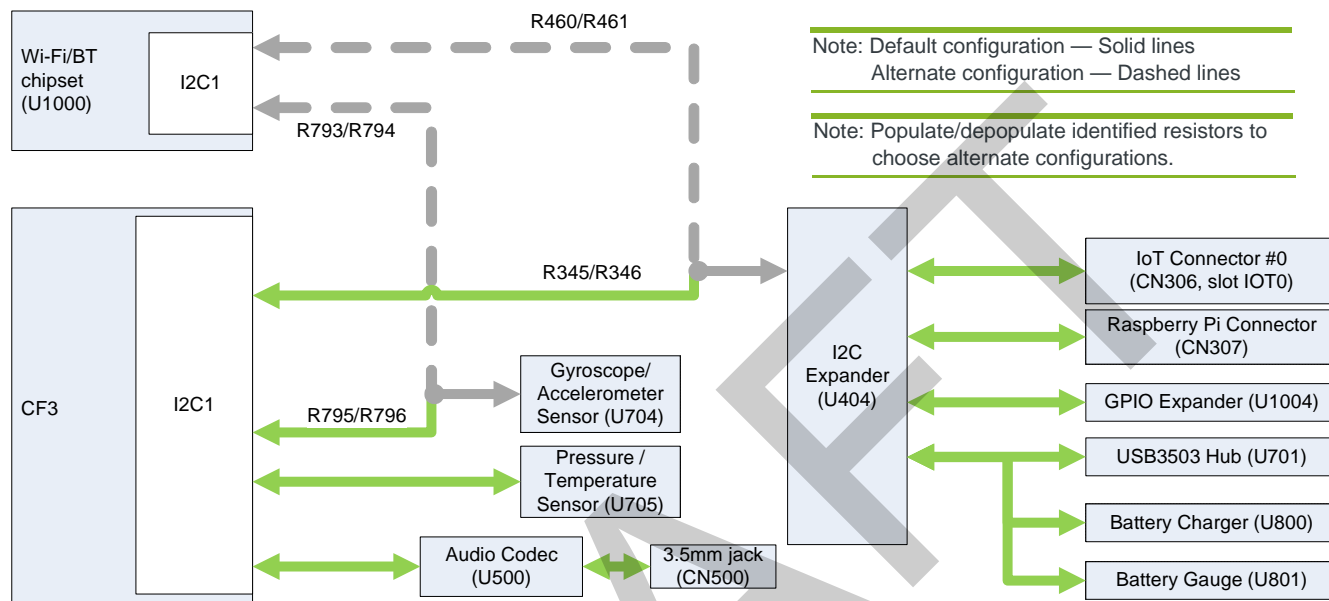

Figure 2-9: I2C1 Configuration

Light Sensor

The mangOH Red provides a light sensor (U706) that connects to the CF3 module's ADC3 signal, as shown in Figure 2-5 on page 16.

Raspberry Pi Rev B-compatible Connector

The mangOH Red provides a 26-pin Raspberry Pi RevB-compatible connector (CN307).

The mangOH Red provides the Raspberry Pi primary signals (alternate Raspberry Pi signals are not supported) as shown in Figure 2-10 on page 22. These signals connect the mangOH Red's hardware components to a Raspberry Pi attached to the connector, as shown in Figure 2-11 on page 22.

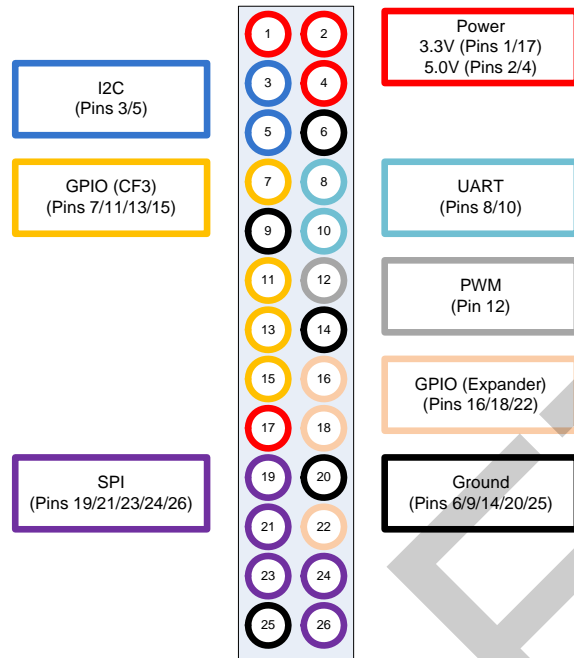

Figure 2-10: Raspberry Pi Signal Groups

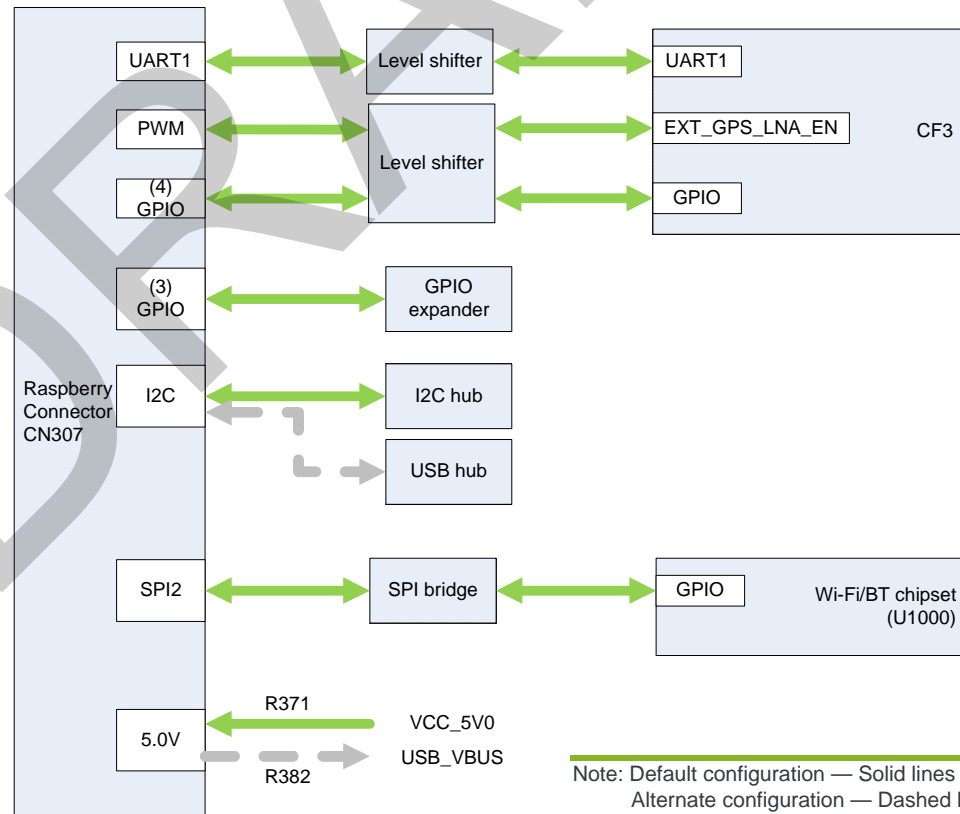

Figure 2-11: Raspberry Pi Connections

RF

The mangOH Red provides u.FL connectors that connect to the CF3 module's RF signals:

- RF_MAIN—CN301
- RF_GPS—CN303
- RF_DIV—CN302

Power for these signals can be enabled/disabled as described in [Table 2-5](#).

Table 2-5: CF3 GPIO Interface Configuration Changes

Change type	Change effect	Method	Change duration
Software	Enable/disable RF power for CF3 module	AT command Legato API	

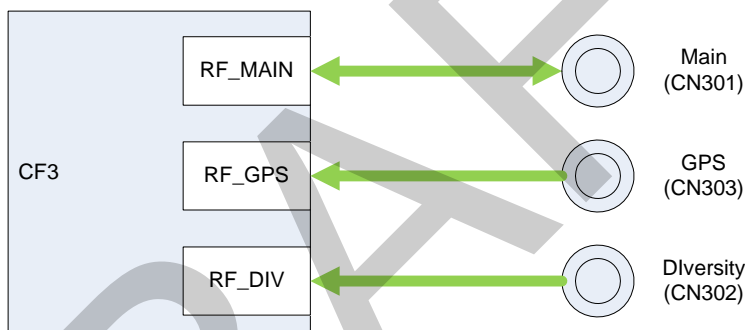

Figure 2-12: CF3 module RF Connections

SDIO

The mangOH Red supports the CF3 module SDIO signals, which connect via a MUX to the following sources, as shown in [Figure 2-13](#) on page 24:

- microSD holder (CN600)—Default configuration
- IOT Connector 0 (CN306)

The SDIO interface configuration can be modified as detailed in [Table 2-6](#).

Table 2-6: SDIO Interface Configuration Changes

Change type	Change effect	Method	Change duration
Software	<ul style="list-style-type: none"> • Use default or alternate configuration. 	API command	Selected configuration used every time device boots up.

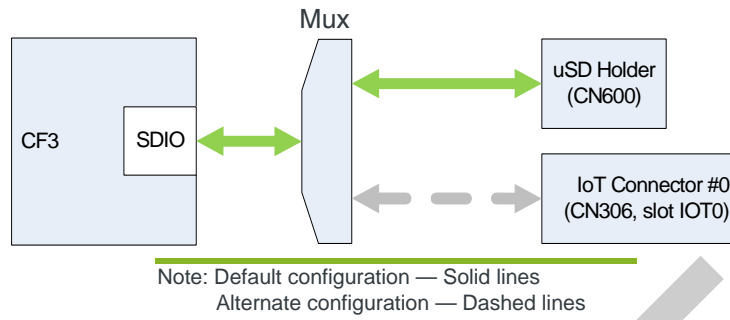

Figure 2-13: SDIO Configuration

SPI1

The mangOH Red supports the CF3 module SPI1 signals, which connect to the following source, as shown in [Figure 2-14](#):

- IOT Connector 0 (CN306)

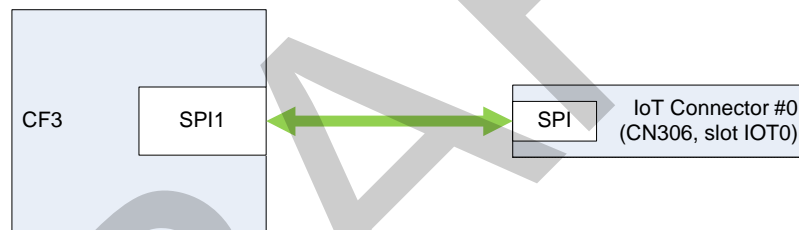

Figure 2-14: SPI1 Configuration

UART1

The mangOH Red supports the CF3 module's UART1 signals, which connect to the following sources, as shown in [Figure 2-15](#) on page 25:

- IoT Connector 0 (CN306)—Default configuration
- Raspberry Pi connector (CN307)
- Wi-Fi/BT chipset (Note, the level shifter must be ON. In the default board configuration, the level shifter is OFF.)

Note: At any one time, use only the IoT expansion card UART or the Raspberry Pi UART, not both.

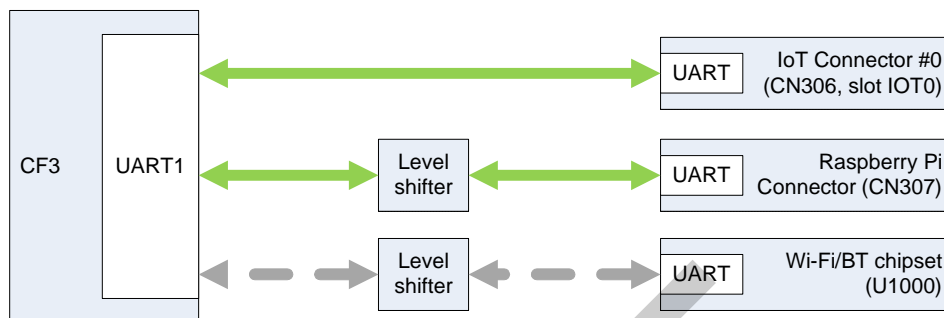

Figure 2-15: UART1 Configuration

UART2

The mangOH Red supports the CF3 module’s UART2 signals, which connect via a MUX to the following sources, as shown in [Figure 2-16](#) on page 26:

- Console USB connector (CN305)—UART2 connects to the physical Console USB connector when both MTK_TO_WP_UART_EN and CONS_DIR are low.
- Wi-Fi/BT chipset’s UART signal (U1000)—CF3 module’s UART2 and Wi-Fi/BT chipset’s UART0 are linked when MTK_TO_WP_UART_EN signal is pulled high.

UART Console Connections

The mangOH Red supports the following console connections for the CF3 module (UART2) and Wi-Fi/BT chipset (UART0), as shown in [Figure 2-16](#) on page 26:

- CF3 module UART2 to Console USB connector (CN305)
- Wi-Fi/BT chipset UART0 to Console USB connector (CN305)
- Direct connect between CF3 module UART2 and Wi-Fi/BT chipset UART0

Table 2-7: UART Console Connection Options

Connection	CONS_DIR (SW401 pin 6)	MTK_TO_WP_UART_EN (API)
CF3 module UART2 to Console USB	Pull low (Pin OFF)	Pull low
Wi-Fi/BT chipset UART0 to Console USB	Pull high (Pin ON)	Pull low
CF3 module UART2 to Wi-Fi/BT chipset UART0	n/a	Pull high

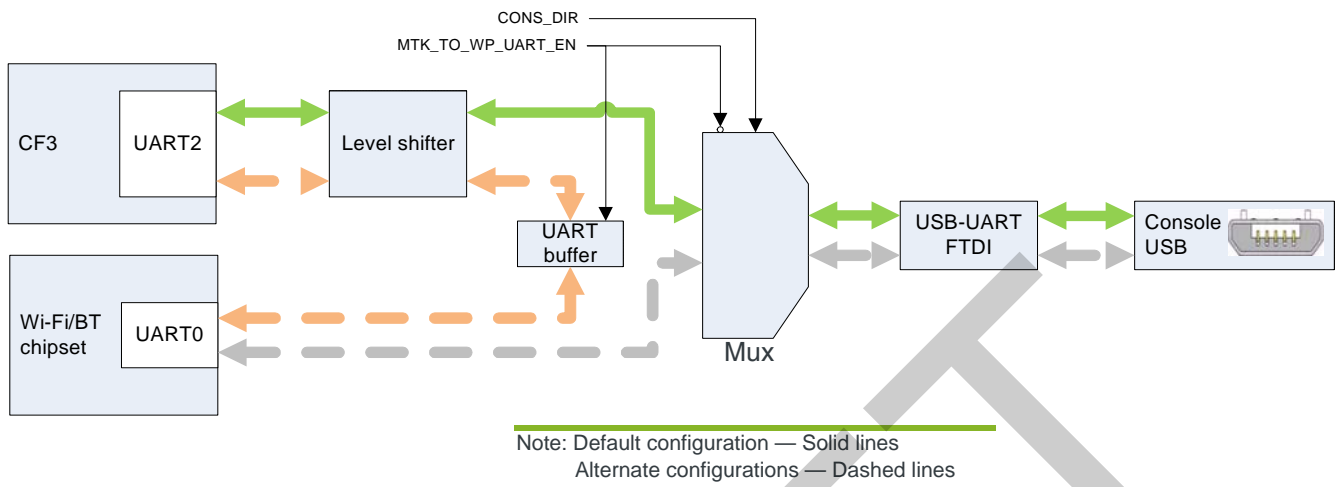

Figure 2-16: UART Console Connections

UIM Signals

The mangOH Red supports both CF3 module UIM interfaces (UIM1, UIM2), where UIM1 is a removable SIM, and UIM2 is an embedded SIM (DNI).

The default boot configuration is shown in [Figure 2-17](#) on page 26.

Note: Throughout this document, 'UIM' is used to refer to UIM, USIM, SIM, UICC.

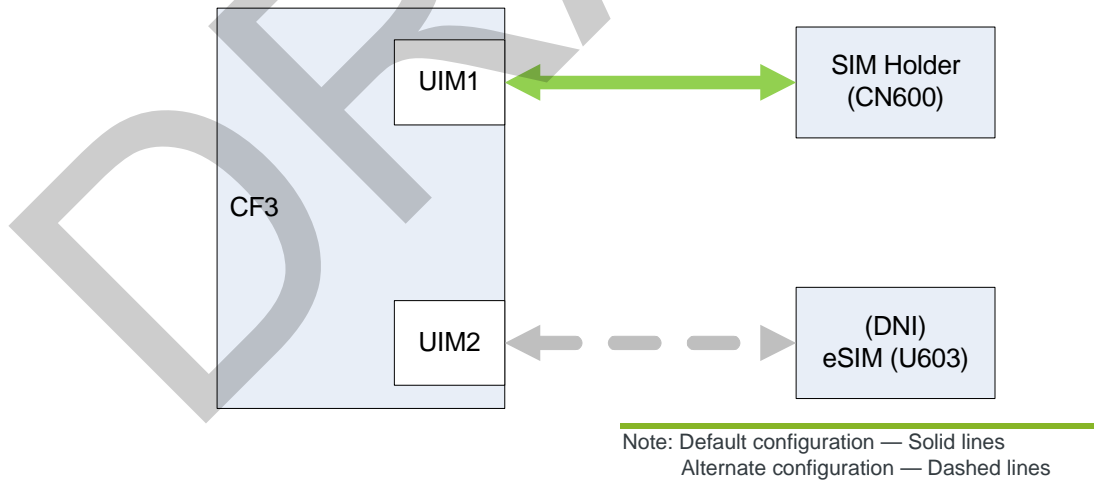

Figure 2-17: SIM Interfaces Configuration

UIM1

The CF3 module's UIM1 signal connects to the micro-SIM holder (CN600).

Note: The CF3 module's UIM1_DET signal indicates when a SIM is present in the holder.

UIM2

Note: The mangOH Red does not ship with an eSIM (the component is DNI). For details, refer to the mangOH Red schematics available at mangoh.io.

The CF3 module's UIM2 signal connects to the eSIM (U603).

Note: The corresponding UIM2_DET signal pin is reserved for future use.

USB 2.0

The CF3 module's USB signal connects directly to the mangOH Red's CF3 USB micro-USB connector (CN305) as shown in [Figure 2-18](#), for control by a connected computer.

Note: The micro-USB connector also acts as a power source, if selected. See [Power Management](#) on page 31.

The USB 2.0 interface configuration can be modified as detailed in [Table 2-8](#).

Table 2-8: USB 2.0 Interface Configuration Methods

Change type	Change effect	Method	Change duration
Hardware	<ul style="list-style-type: none"> Jumper on pins closest to CF3 USB—Select CF3 USB power Jumper on pins closest to Console USB—Select Console USB power Jumper off—Use battery if connected, otherwise no power supplied 	Position jumper on CN804 to choose CF3 USB or CONSOLE USB connector to supply power. <i>Note: mangOH Red ships with CF3 USB power selected (jumper on pins closest to CF3 USB connector).</i>	mangOH Red uses the selected power supply until the jumper changes.

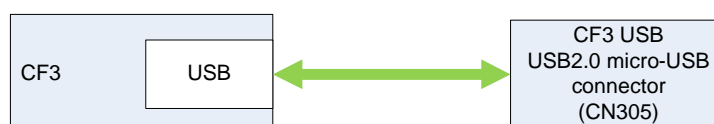

Figure 2-18: USB_2.0 Configuration

Wi-Fi/BT Chipset

The mangOH Red incorporates a Wi-Fi/BT chipset (MediaTek Wi-Fi+Bluetooth) that provides the following functionality:

- RF—Wi-Fi/Bluetooth/WLAN connections via an integrated 2.4 GHz antenna
- IOT0 connection via Wi-Fi/BT chipset's UART1
- Application processor—Real-time application processing using the mangOH Red's real-time I/O connector, via GPIO, ADC, and I2C interfaces.
- Access to mangOH Red's accelerometer/gyroscope/temperature sensor via GPIO interface
- Access to Raspberry Pi connector via SPI interface
- Wi-Fi/BT chipset console connection to either the Console USB connector or the CF3 module console, including ability to receive firmware downloads from either source.
- Optional debug connector (CN400, DNI) to use for serial wire debugging

The Wi-Fi/BT chipset can connect to several components on the mangOH Red, as show in [Figure 2-19](#) on page 29.

DRAFT

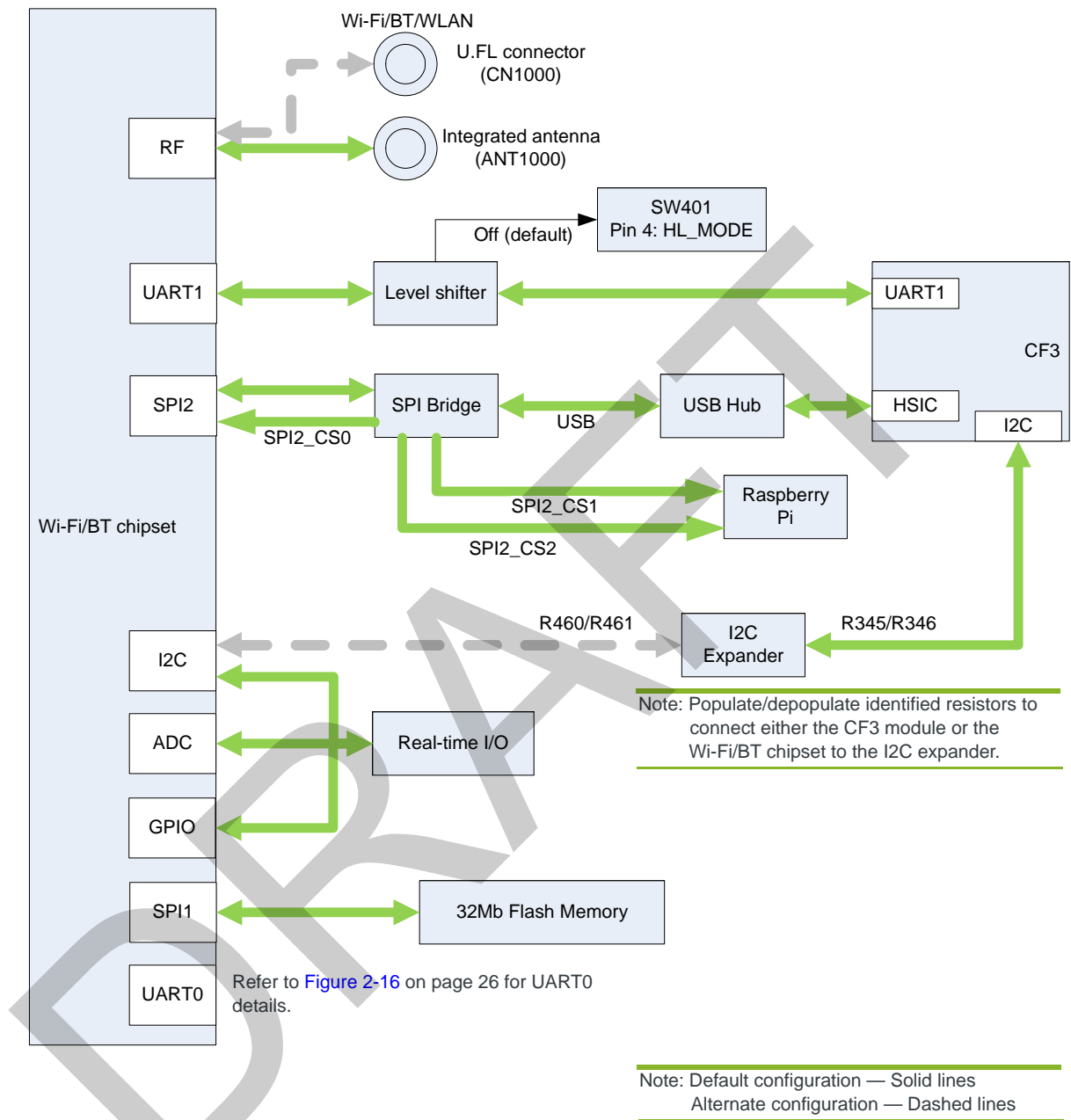

Figure 2-19: Wi-Fi/BT Chipset Connections

IoT Connector Interfaces

The mangOH Red provides one IoT Connector (CN306, slot IOT0), which supports the signals defined in the Project mangOH IoT Expansion Card Design Specification, as detailed in [Table 2-2](#) on page 15.

The default configuration (enabled signals) for the IoT Connector is shown in [Figure 2-20](#).

The IoT Connector interface configuration can be modified as detailed in [Table 2-9](#).

Table 2-9: IoT Connector Interface Configuration Changes

Change type	Change effect	Method	Change duration
Software	Enable/disable identified signal(s) on a specific IoT Connector.	API command	Modifies running configuration until device reboots or another change is made.

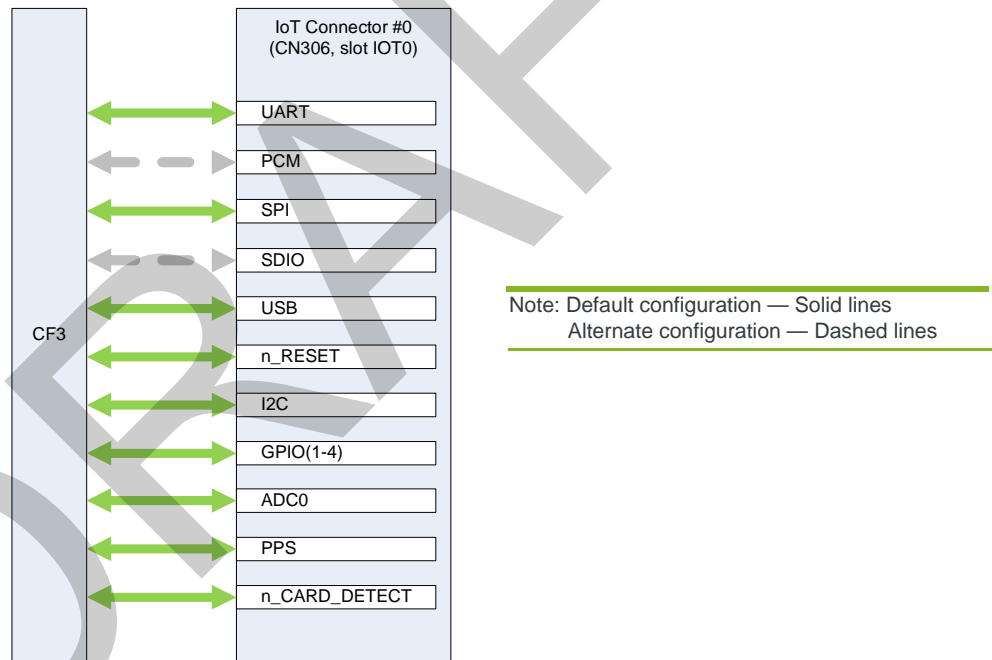

Figure 2-20: IoT Connector Configuration

Reset Methods

The mangOH Red supports hardware and software resets of the entire board or certain components of the board, as shown in [Figure 2-21](#):

Table 2-10: Reset Methods

Board Components to Reset	Reset Method
Entire board, including CF3 module	<ul style="list-style-type: none"> SW401 pin 4 ON Press Reset button (SW400)
Entire board, excluding CF3 module	<ul style="list-style-type: none"> SW401 pin 4 OFF Press Reset button (SW400)
IOT Expansion Card	CF3_IOT0_RESET or Use an API command to trigger the CF3 module signal GPIO_IOT0_RESET.
Wi-Fi/BT chipset	CF3_GPIO_WIFI_RESET

For detailed specifications showing how full or partial resets are enabled, see the mangOH Red schematics available at mangoh.io.

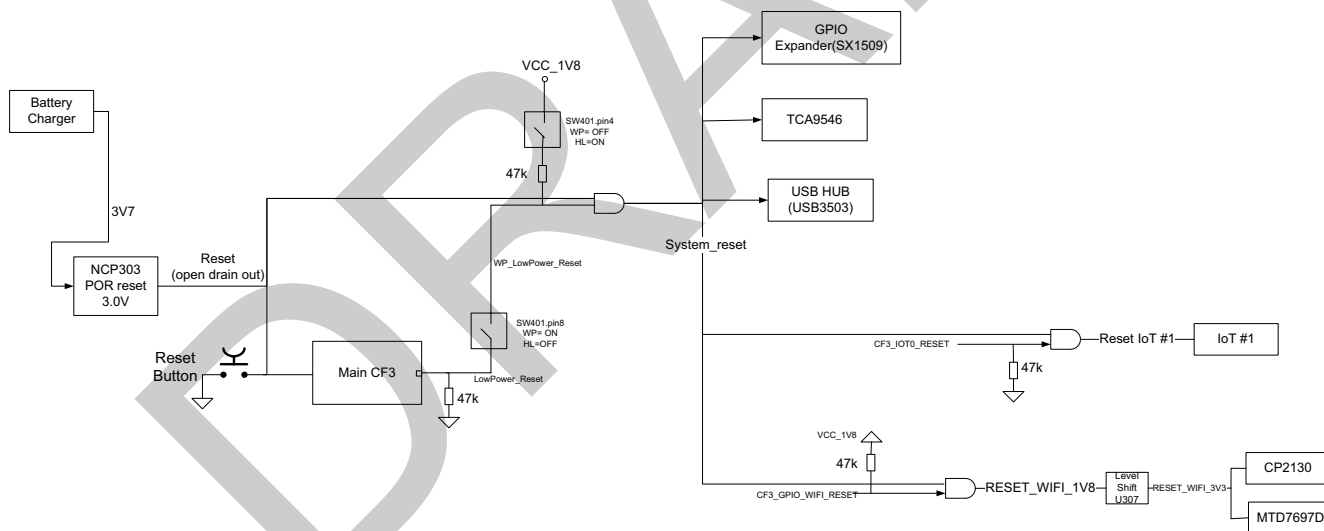

Figure 2-21: Reset Methods

Power Management

The mangOH Red has two primary power supplies (CF3 USB connector and CONSOLE USB connector), and a rechargeable backup battery power supply option.

[Figure 2-22](#) illustrates these power supplies, their voltage/current specifications, and how they supply various components on the mangOH Red platform.

A multi-function switch (SW401) controls some power-related features (see [Multi-switch \(SW401\)](#) on page 14), including:

- Pin 1 (PWR_ON)—Enable/disable CF3 module's POWER_ON_signal
- Pin 3 (VCC_3V7_ULPM)—In ULPM, enable/disable power to accessories (CF3 module always receives power)
- Pin 5 (BATT_TS+)—Enable/disable backup battery charging

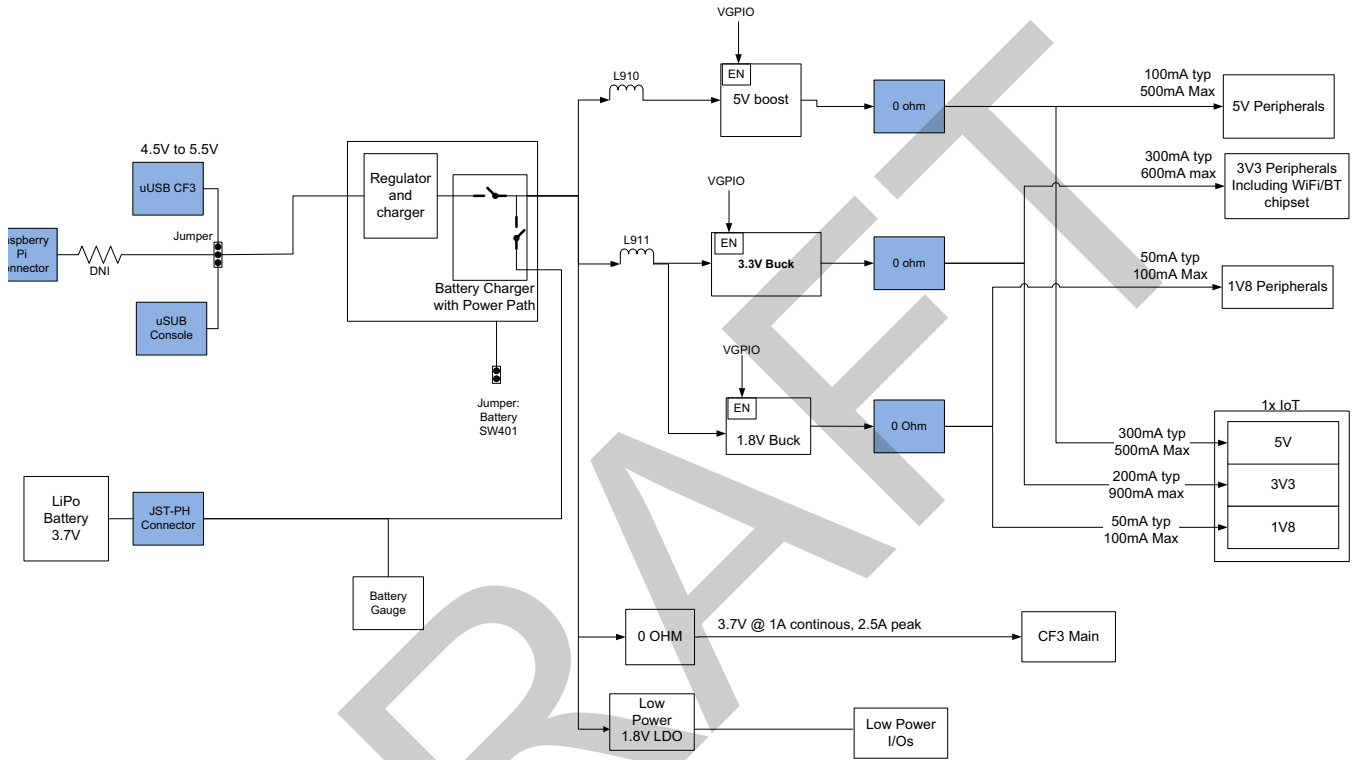

Figure 2-22: Power Management